

ULTRA SV/SL/SLX

Multistage Vertical

Stainless steel multistage vertical pumps. Pumping of clean non-loaded fluids, pressurizing system, irrigation, drinking and glycol water, water treatment, food industry, heating and air conditioning, washing system.



ULTRA SV



ULTRA 3-5-7 SL



ULTRA 9-18 SL



ULTRA SLX



Construction features

Pump body	cast iron (SV/SL); stainless steel AISI 304 (SLX)
Motor bracket	cast iron
Impellers, diffusers, shell, motor shaft	stainless steel AISI 304
Mechanical seal	ceramic-graphite-EPDM graphite-silicon carbide-EPDM
Intermediate shaft guiding stage bush	ceramic-tungsten carbide
Ambient temperature	max 40 °C
Liquid temperature	+5 ÷ 90 °C (SV) -15 ÷ 110 °C (SL/SLX)
Max operating pressure	8 bar ≤ 6 impellers; 14 bar ≥ 7 impellers
Pump body gasket	EPDM

Motor

2 pole induction motor	3~ 230/400V - 50Hz P ≤ 4kW 3~ 400/690V - 50Hz P > 4kW
	1- 230V-50Hz (with thermal protection up to 1,85 kW)
Insulation class	F
Protection degree	IPX4 IPX5 ≥ 4,5 HP

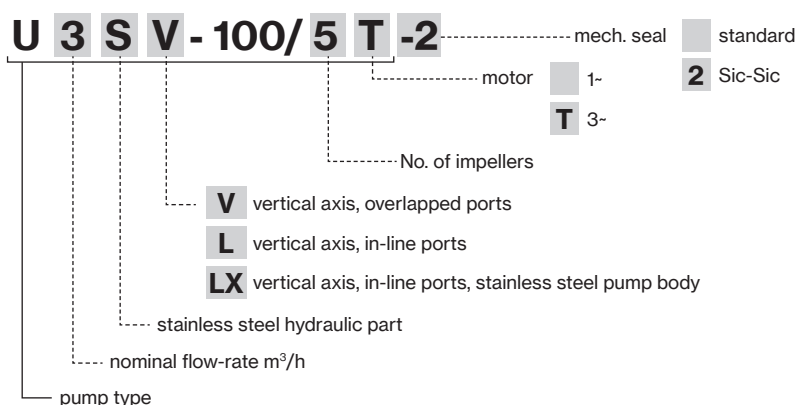

ULTRA SV/SL/SLX

TYPE		P2		P1 (kW)		AMPERE		Q (m³/h - l/min)						
1~	3~					1~	3~	0	0,6	1,2	1,8	2,4	3,6	4,8
								0	10	20	30	40	60	80
		HP	kW	1~	3~	1- 230V 50 Hz	3-400V 50 Hz	H (m)						
U 3...-100/5	U 3...-100/5T	1	0,75	1	0,9	4,4	1,7	55,3	53,5	50,3	46,5	42,1	31,6	17,7
U 3...-120/6	U 3...-120/6T	1,2	0,9	1,1	1,1	5,1	2,5	66,6	64,4	60,8	56,0	50,7	38,1	22,4
U 3...-150/7	U 3...-150/7T	1,5	1,1	1,4	1,4	6,6	3,1	75,6	73,3	69,4	64,8	58,9	44,4	26,1
U 3...-180/8	U 3...-180/8T	2	1,5	1,5	1,5	7,0	3,2	86,7	83,9	79,3	73,9	67,3	51,0	29,9
U 3...-200/9	U 3...-200/9T	2	1,5	1,7	1,6	7,6	3,3	97,0	93,8	88,5	82,5	74,7	56,4	32,9
U 3...-250/10	U 3...-250/10T	2	1,5	1,9	1,7	8,6	3,5	107,2	103,4	97,3	90,5	82,0	61,5	35,6
U 3...-280/11	U 3...-280/11T	2,5	1,85	2,1	1,9	9,8	3,9	117,2	112,8	106,6	98,8	89,8	66,8	37,3
U 3...-300/12	U 3...-300/12T	2,5	1,85	2,2	2,1	10,2	4,1	126,4	121,3	114,5	106,1	95,9	71,7	40,0

TYPE		P2		P1 (kW)		AMPERE		Q (m³/h - l/min)							
1~	3~					1- 230V 50 Hz	3-400V 50 Hz	0	1,8	2,4	3,6	4,8	6	7,2	8,4
								0	30	40	60	80	100	120	140
		HP	kW	1~	3~	H (m)									
U 5...-120/4	U 5...-120/4T	1,2	0,9	1,09	1,09	4,9	2,4	45,5	42,2	40,7	37,2	32,9	27,4	19,8	10,4
U 5...-150/5	U 5...-150/5T	1,5	1,1	1,4	1,3	6,6	3,1	55,9	52,8	51,4	48,1	43,4	37,3	28,3	16,4
U 5...-180/6	U 5...-180/6T	2	1,5	1,6	1,6	7,4	3,3	67,0	63,3	61,6	57,6	51,9	44,2	33,6	20,4
U 5...-200/7	U 5...-200/7T	2	1,5	1,9	1,8	8,6	3,6	77,8	73,5	71,3	66,3	59,6	50,7	38,0	22,4
U 5...-250/8	U 5...-250/8T	2,5	1,85	2,2	2,1	9,9	4,1	89,2	83,9	81,6	76,2	68,4	58,3	43,2	24,6
U 5...-280/9	U 5...-280/9T	2,5	1,85	2,4	2,3	10,9	4,3	99,7	93,7	90,9	84,1	75,2	64,1	47,4	25,9
U 5...-300/10	U 5...-300/10T	3	2,2	2,7	2,6	12,5	4,9	112,2	105,4	102,4	95,3	85,6	72,6	54,8	31,0
U 5...-350/11	U 5...-350/11T	3,5	2,57	3,0	2,9	13,7	5,3	125,1	117,6	114,3	106,1	95,5	80,9	60,9	34,8
-	U 5...-380/12T	4	3	-	3,2	-	6,0	135,7	128,9	125,6	117,7	106,3	91,3	70,2	41,5

TYPE		P2		P1 (kW)		AMPERE		Q (m³/h - l/min)						
1~	3~					1- 230V 50 Hz	3-400V 50 Hz	0	2,4	3,6	4,8	6	7,2	9,6
								0	40	60	80	100	120	160
		HP	kW	1~	3~	H (m)								
U 7...-180/4	U 7...-180/4T	2	1,5	1,8	1,7	8,3	3,5	46,7	46,0	45,2	43,1	40,3	36,9	25,5
U 7...-250/5	U 7...-250/5T	2,5	1,85	2,2	2,1	9,9	4,0	58,5	57,6	56,6	54,1	50,8	46,1	31,8
U 7...-300/6	U 7...-300/6T	3	2,2	2,6	2,5	12,1	4,8	70,6	69,9	68,7	65,8	61,8	56,6	39,3
-	U 7...-350/7T	3,5	2,57	-	2,9	-	5,3	82,8	82,0	80,6	77,2	72,3	66,0	46,4
-	U 7...-400/8T	4	3	-	3,3	-	6,1	94,8	94,3	92,5	88,6	83,2	76,4	52,6
-	U 7...-450/9T	4,5	3,37	-	3,7	-	6,7	107,4	106,9	105,2	101,1	95,3	87,7	61,0
-	U 7...-550/10T	5,5	4	-	4,1	-	7,9	119,8	119,6	118,4	113,9	107,7	99,4	70,4

TYPE		P2		P1 (kW)		AMPERE		Q (m³/h - l/min)							
1~	3~					1- 230V 50 Hz	3-400V 50 Hz	0	3,6	4,8	6	7,2	9,6	12	13,2
								0	60	80	100	120	160	200	220
		HP	kW	1~	3~	H (m)									
U 9...-200/4	U 9...-200/4T	2	1,5	1,8	1,8	8,3	3,6	45,8	42,7	41,5	39,7	37,8	32,7	24,6	19,8
U 9...-250/5	U 9...-250/5T	2,5	1,85	2,3	2,2	10,4	4,2	57,1	53,1	51,6	49,5	47,2	40,6	30,2	24,4
U 9...-300/6	U 9...-300/6T	3	2,2	2,8	2,6	12,8	5,0	69,4	64,7	63,0	60,3	57,3	49,8	36,2	28,1
-	U 9...-400/7T	4	3	-	3,1	-	5,9	82,0	77,2	74,9	72,0	68,7	59,9	44,2	33,9
-	U 9...-450/8T	4,5	3,37	-	3,6	-	6,5	93,5	88,5	86,3	82,6	79,0	69,5	52,0	41,7
-	U 9...-500/9T	4,5	3,37	-	4	-	7	105,4	99,1	96,5	92,5	88,3	77,3	57,5	46,9
-	U 9...-550/10T	5,5	4	-	4,4	-	8,2	117,6	111,2	108,7	104,5	99,9	87,8	66,2	53,4

TYPE		P2		P1 (kW)		A		Q (m³/h - l/min)							
3~	3~					0	6	7,2	9,6	12	14,4	16,8	19,2	21,6	24
						0	100	120	160	200	240	280	320	360	400
		HP	kW	3~	3-400V 50 Hz	H (m)									
U 18...-250/3T		2,5	1,85	2,3	4,3	33,8	31,6	31,0	29,4	27,4	25,4	23,2	20,4	16,3	11,5
U 18...-400/4T		4	3	3,1	5,9	46,3	44,2	43,4	41,4	39,1	36,7	34,1	30,8	25,6	19,0
U 18...-450/5T		4,5	3,37	3,9	6,9	58,1	55,7	54,6	52,1	49,3	46,3	42,9	38,7	32,2	24,0
U 18...-550/6T		5,5	4	4,7	8,5	70,1	67,4	66,3	63,4	60,0	56,4	52,4	47,6	39,6	29,9
U 18...-750/8T		7,5	5,5	6,2	11,2	94,2	90,6	89,1	85,3	80,9	76,2	71,1	65,0	54,6	41,4
U 18...-900/9T		10	7,5	7	12,9	106,4	102,8	101,3	97,2	92,4	87,3	81,6	75,0	63,5	48,5



ULTRA SV/SL/SLX

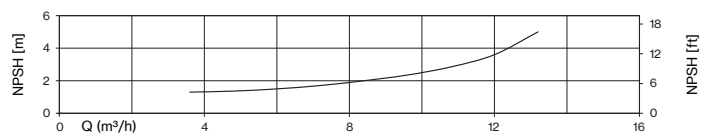
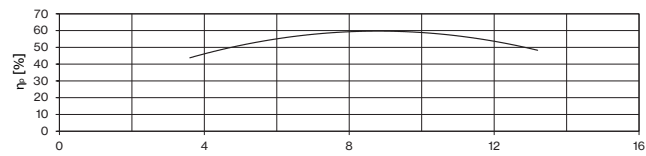
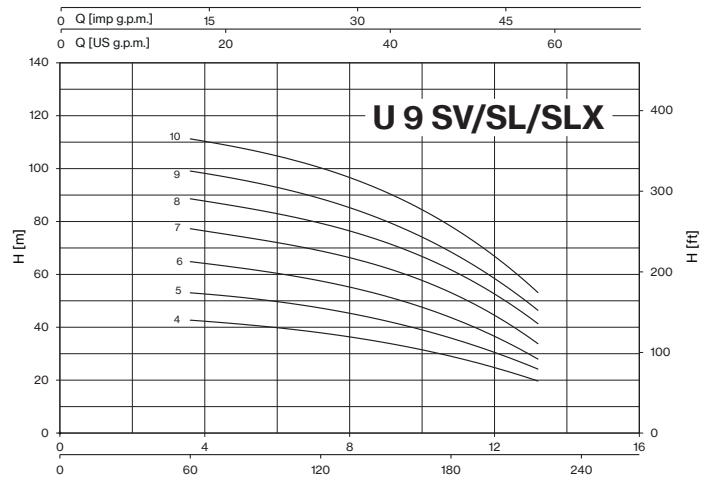
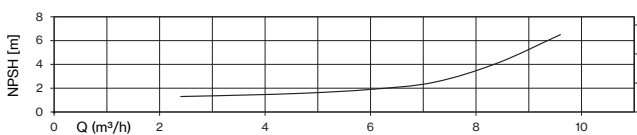
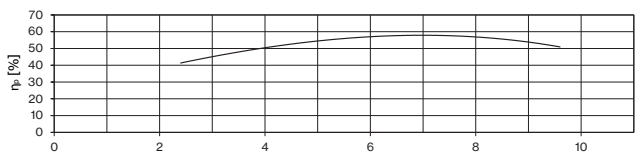
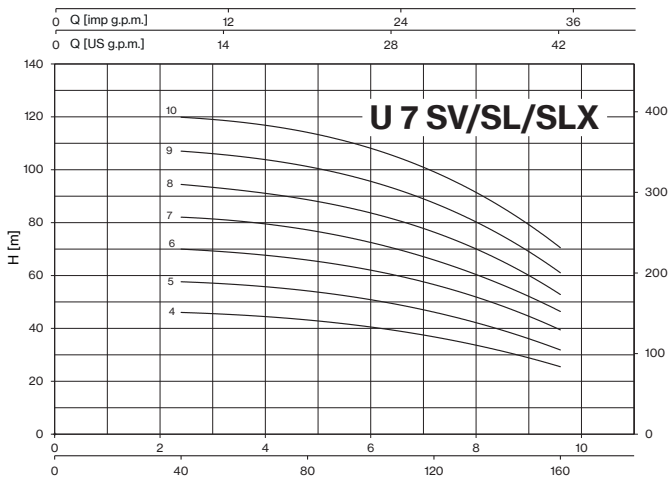
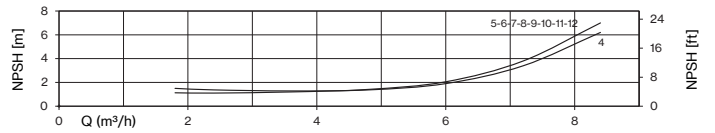
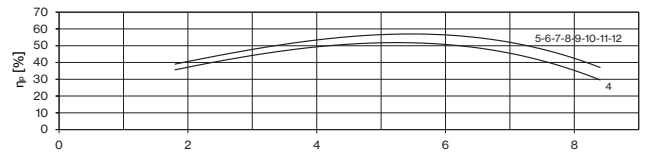
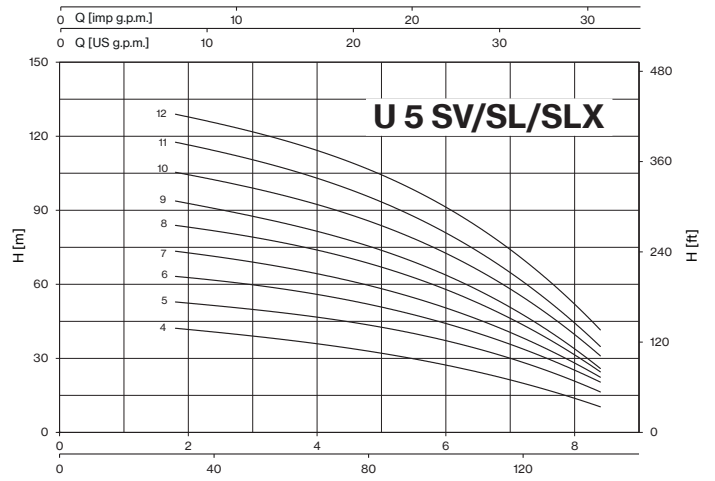
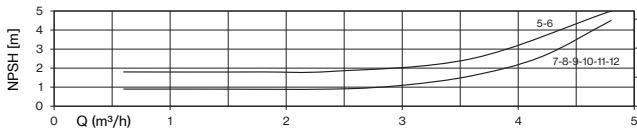
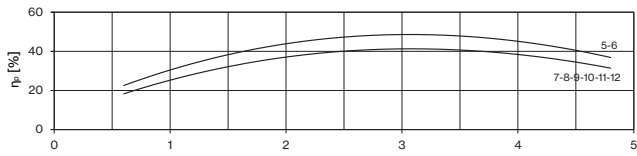
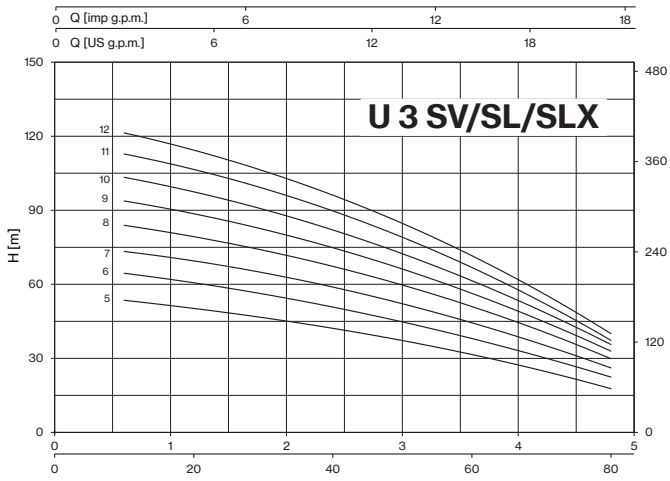

ULTRA SV/SL/SLX

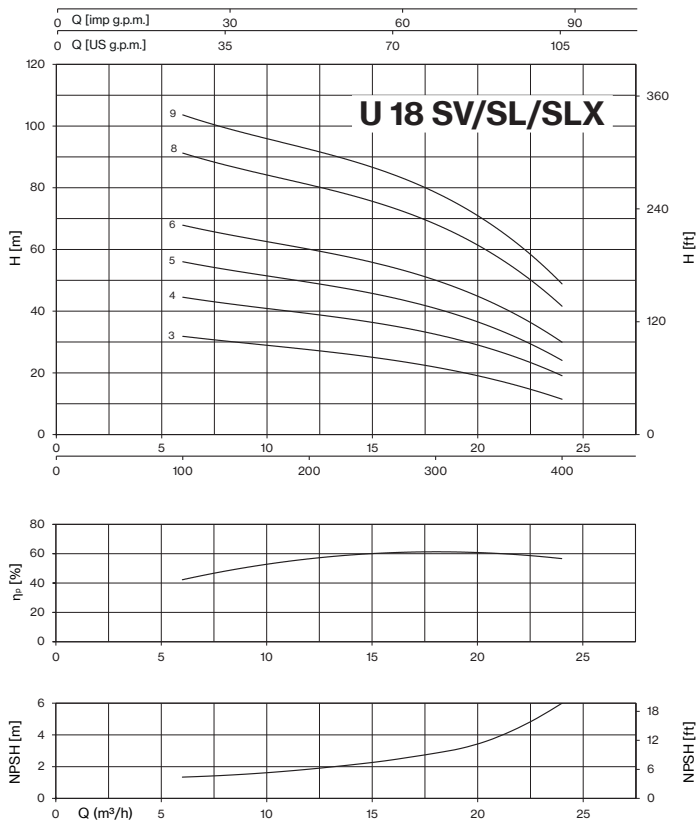

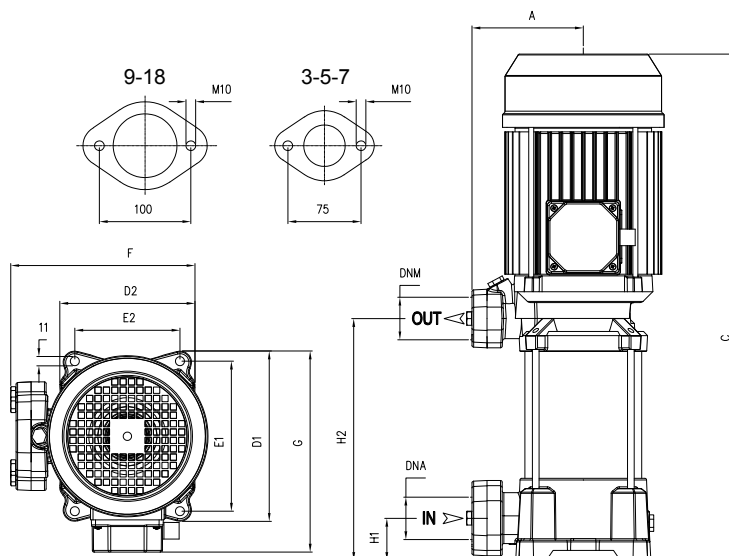

TYPE		DIMENSIONS (mm)												Kg	
-1	-3	A	C	D1	D2	E1	E2	F	G	H1	H2	DNA	DNM	-1	-3
U 3SV-100/5	U 3SV-100/5T	135	413	204	162	178,5	125	229	213	40	178	1" ¼ G	1" ¼ G	18,5	18,5
U 3SV-120/6	U 3SV-120/6T	135	437	204	162	178,5	125	229	213	40	202			19,5	19,5
U 3SV-150/7	U 3SV-150/7T	135	521	204	162	178,5	125	229	220	40	226			26,5	26,5
U 3SV-180/8	U 3SV-180/8T	135	545	204	162	178,5	125	229	220	40	250			26,5	26,5
U 3SV-200/9	U 3SV-200/9T	135	569	204	162	178,5	125	229	220	40	274			27,5	27,5
U 3SV-250/10	U 3SV-250/10T	135	593	204	162	178,5	125	229	220	40	298			28,5	28,5
U 3SV-280/11	U 3SV-280/11T	135	672 T 617	204	162	178,5	125	229	228 T 220	40	322			32	29
U 3SV-300/12	U 3SV-300/12T	135	696 T 641	204	162	178,5	125	229	228 T 220	40	346	32,5	28		
U 5SV-120/4	U 5SV-120/4T	135	389	204	162	178,5	125	229	213	40	178	1" ¼ G	1" ¼ G	18,5	18,5
U 5SV-150/5	U 5SV-150/5T	135	473	204	162	178,5	125	229	220	40	202			25,5	25,5
U 5SV-180/6	U 5SV-180/6T	135	497	204	162	178,5	125	229	220	40	226			26	26
U 5SV-200/7	U 5SV-200/7T	135	521	204	162	178,5	125	229	220	40	250			25,5	26,5
U 5SV-250/8	U 5SV-250/8T	135	545	204	162	178,5	125	229	220	40	274			27	26
U 5SV-280/9	U 5SV-280/9T	135	624 T 569	204	162	178,5	125	229	228 T 220	40	298			31	26,5
U 5SV-300/10	U 5SV-300/10T	135	648 T 593	204	162	178,5	125	229	228 T 220	40	322			35,5	28
U 5SV-350/11	U 5SV-350/11T	135	672	204	162	178,5	125	229	228	40	346	36	33		
-	U 5SV-380/12T	135	696	204	162	178,5	125	229	228	40	370	-	35,5		
U 7SV-180/4	U 7SV-180/4T	135	422	204	162	178,5	125	229	220	40	178	1" ¼ G	1" ¼ G	23,5	25
U 7SV-250/5	U 7SV-250/5T	135	473	204	162	178,5	125	229	220	40	202			25	24
U 7SV-300/6	U 7SV-300/6T	135	552 T 497	204	162	178,5	125	229	228 T 220	40	226			32,5	26
-	U 7SV-350/7T	135	575	204	162	178,5	125	229	228	40	250			-	30
-	U 7SV-400/8T	135	600	204	162	178,5	125	229	228	40	274			-	33,5
-	U 7SV-450/9T	135	653	204	162	178,5	125	235	243	40	301			-	39
-	U 7SV-550/10T	135	676	204	162	178,5	125	235	243	40	325			-	44
U 9SV-200/4	U 9SV-200/4T	135	473	204	162	178,5	125	229	220	40	202	1" ½ G	1" ¼ G	24	25
U 9SV-250/5	U 9SV-250/5T	135	503	204	162	178,5	125	229	220	40	232			25,5	24,5
U 9SV-300/6	U 9SV-300/6T	135	588 T 533	204	162	178,5	125	229	228 T 220	40	262			33	26,5
-	U 9SV-400/7T	135	617	204	162	178,5	125	229	228	40	292			-	33,5
-	U 9SV-450/8T	135	677	204	162	178,5	125	235	243	40	325			-	39
-	U 9SV-500/9T	135	707	204	162	178,5	125	235	243	40	355			-	39,5
-	U 9SV-550/10T	135	737	204	162	178,5	125	235	243	40	385			-	45
-	U 18SV-250/3T	135	481	204	162	178,5	125	229	220	50	211	2" G	1" ½ G	-	25
-	U 18SV-400/4T	135	573	204	162	178,5	125	229	228	50	248			-	33,5
-	U 18SV-450/5T	135	640	204	162	178,5	125	235	243	50	289			-	39,5
-	U 18SV-550/6T	135	678	204	162	178,5	125	235	243	50	326			-	44,5
-	U 18SV-750/8T	135	815	204	162	178,5	125	255	253	50	401			-	55,5
-	U 18SV-900/9T	135	852	204	162	178,5	125	255	253	50	439			-	62



ULTRA SL/SLX

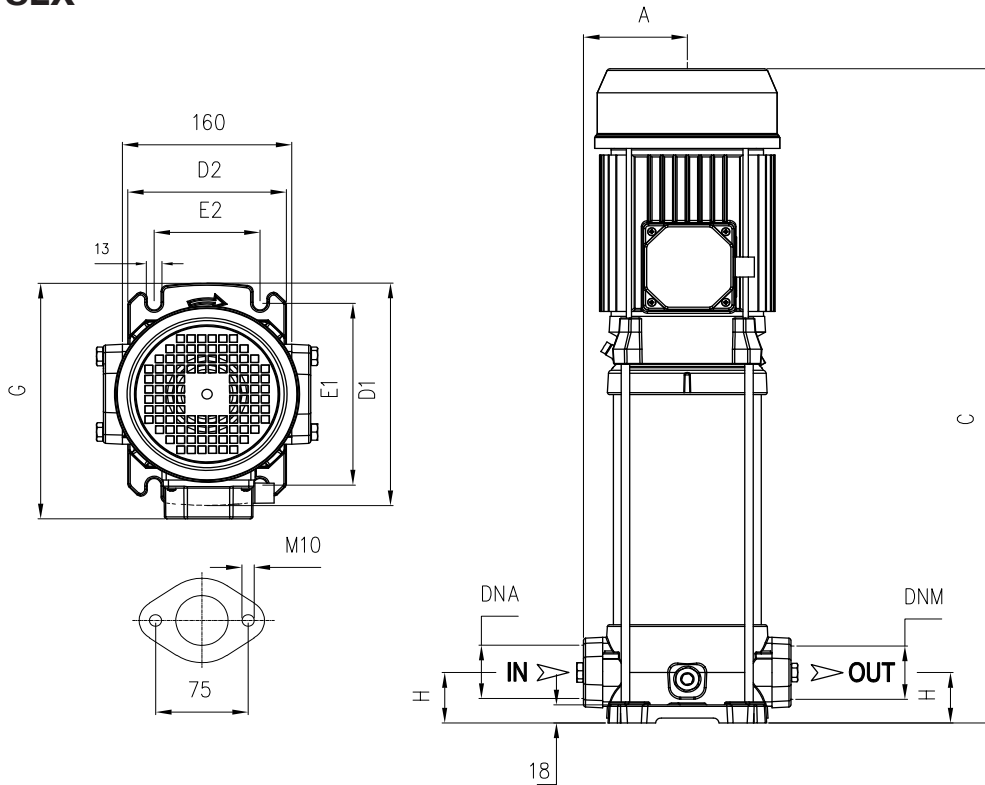

TYPE		DIMENSIONS (mm)										Kg			
		A	C	D1	D2	E1	E2	G	H	DNA	DNM	SL		SLX	
-1	-3											-1	-3	-1	-3
U 3...-100/5	U 3...-100/5T	98	429	220	150	180	100	228	50	1" ¼ G	1" ¼ G	19	19	19	19
U 3...-120/6	U 3...-120/6T	98	453	220	150	180	100	228	50			21,5	21,5	20	20
U 3...-150/7	U 3...-150/7T	98	537	220	150	180	100	228	50			28,5	28,5	27,5	27,5
U 3...-180/8	U 3...-180/8T	98	561	220	150	180	100	228	50			28,5	28,5	27,5	27,5
U 3...-200/9	U 3...-200/9T	98	585	220	150	180	100	228	50			30,5	30,5	29	29,5
U 3...-250/10	U 3...-250/10T	98	609	220	150	180	100	228	50			31,5	31,5	30,5	30,5
U 3...-280/11	U 3...-280/11T	98	688 T 633	220	150	180	100	236 T 228	50	1" ¼ G	1" ¼ G	35,5	32,5	34	31
U 3...-300/12T	U 3...-300/12T	98	712 T 657	220	150	180	100	236 T 228	50			36	31,5	34,5	30
U 5...-120/4	U 5...-120/4T	98	405	220	150	180	100	221	50			1" ¼ G	1" ¼ G	20	20
U 5...-150/5	U 5...-150/5T	98	489	220	150	180	100	228	50	27,5	27,5			26,5	26,5
U 5...-180/6	U 5...-180/6T	98	513	220	150	180	100	228	50	28	28			26,5	27
U 5...-200/7	U 5...-200/7T	98	537	220	150	180	100	228	50	27,5	28,5			26	27,5
U 5...-250/8	U 5...-250/8T	98	561	220	150	180	100	228	50	29	28			28	27
U 5...-280/9	U 5...-280/9T	98	640 T 585	220	150	180	100	236 T 228	50	34	29,5			33	28,5
U 5...-300/10	U 5...-300/10T	98	664 T 609	220	150	180	100	236 T 228	50	1" ¼ G	1" ¼ G	37,5	31	36,5	30
U 5...-350/11	U 5...-350/11T	98	687	220	150	180	100	236	50			38,5	35,5	37	34
-	U 5...-380/12T	98	711	220	150	180	100	236	50			-	39	-	37,5
U 7...-180/4	U 7...-180/4T	98	465	220	150	180	100	228	50	1" ¼ G	1" ¼ G	26	27	24,5	6
U 7...-250/5	U 7...-250/5T	98	489	220	150	180	100	228	50			27,5	26,5	26	25
U 7...-300/6	U 7...-300/6T	98	568 T 513	220	150	180	100	236 T 228	50			35	28	34	27
-	U 7...-350/7T	98	590	220	150	180	100	236	50			-	33	-	32
-	U 7...-400/8T	98	614	220	150	180	100	236	50			-	36,5	-	35,5
-	U 7...-450/9T	98	668	220	150	180	100	251	50			-	41	-	40
-	U 7...-550/10T	98	692	220	150	180	100	251	50	-	46,5	-	45		



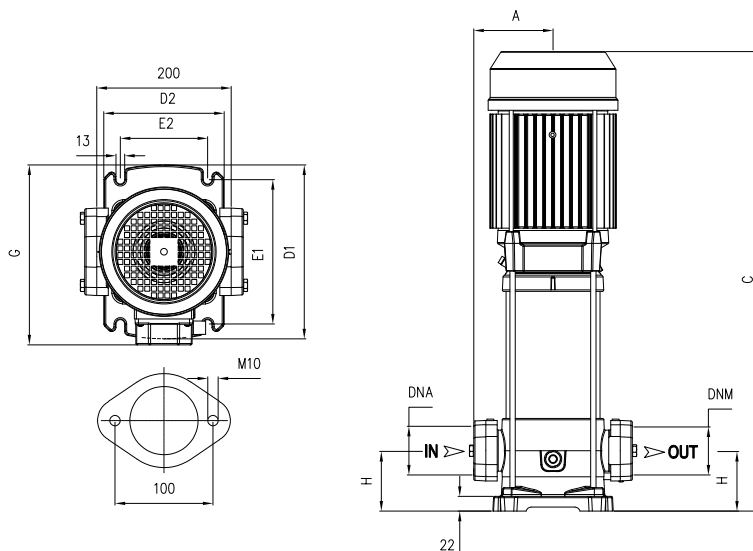

TYPE		DIMENSIONS (mm)										Kg			
												SL		SLX	
-1	-3	A	C	D1	D2	E1	E2	G	H	DNA	DNM	-1	-3	-1	-3
U 9...-200/4	U 9...-200/4T	118	520	260	180	215	130	248	80	1" 1/2 G	1" 1/2 G	30	31	28,5	29,5
U 9...-250/5	U 9...-250/5T	118	550	260	180	215	130	248	80			32	31	30,5	29,5
U 9...-300/6	U 9...-300/6T	118	635 T 580	260	180	215	130	256 T 248	80			39,5	33	38	31,5
-	U 9...-400/7T	118	663	260	180	215	130	256	80			-	40	-	38,5
-	U 9...-450/8T	118	723	260	180	215	130	271	80			-	45	-	43,5
-	U 9...-500/9T	118	763	260	180	215	130	271	80			-	45,5	-	44
-	U 9...-550/10T	118	783	260	180	215	130	271	80			-	51	-	49
-	U 18...-250/3T	118	482	260	180	215	130	251	90	2" G	2" G	-	30,5	-	29,5
-	U 18...-400/4T	118	603	260	180	215	130	257	90			-	39	-	37,5
-	U 18...-450/5T	118	680	260	180	215	130	271	90			-	44,5	-	43
-	U 18...-550/6T	118	718	260	180	215	130	271	90			-	49,5	-	48
-	U 18...-750/8T	118	855	260	180	215	130	280	90			-	60	-	58,5
-	U 18...-900/9T	118	893	260	180	215	130	280	90			-	66,5	-	65

MODEL	LOTS			
	TRUCK		CONTAINER	
	PALLET (cm)	N° pumps	PALLET (cm)	N° pumps
U 3SV-100/5-200/9	80×120×150	42	80×120×175	49
U 3SV-250/10-300/12	80×120×155	30	80×120×180	35
U 3SV-300/12T	80×120×150	42	80×120×175	49
U 5SV-120/4-250/8	80×120×150	42	80×120×175	49
U 5SV-280/9T-300/10T	80×120×150	42	80×120×175	49
U 5SV-280/9-300/10	80×120×155	30	80×120×180	35
U 5SV-350/11-380/12T	80×120×155	30	80×120×180	35
U 7SV-180/4-350/7T	80×120×150	42	80×120×175	49
U 7SV-400/8T	80×120×155	30	80×120×180	35
U 7SV-450/9T-550/10T	85×110×125	20	85×110×150	24
U 9SV-200/4	80×120×150	42	80×120×175	49
U 9SV-250/5-300/6T	80×120×150	42	80×120×175	49
U 9SV-300/6-400/7T	80×120×155	30	80×120×180	35
U 9SV-450/8 T-550/10T	85×110×125	20	85×110×150	24
U 18SV-250/3T-400/4T	80×120×150	42	80×120×175	49
U 18SV-450/5T-550/6T	85×110×125	20	85×110×150	24
U 18SV-750/8T-900/9T	100×120×150	12	100×120×150	12

MODEL	LOTS			
	TRUCK		CONTAINER	
	PALLET (cm)	N° pumps	PALLET (cm)	N° pumps
U 3SL/SLX-100/5-180/8	85×110×150	36	85×110×170	42
U 3SL/SLX-200/9-300/12	80×120×150	30	80×120×170	35
U 5SL/SLX-120/4-250/8	85×110×150	36	85×110×170	42
U 5SL/SLX-280/9-380/12T	80×120×150	30	80×120×170	35
U 7SL/SLX-180/4-300/6T	85×110×150	36	85×110×170	42
U 7SL/SLX-300/6-400/8T	80×120×150	30	80×120×170	35
U 7SL/SLX-450/9 T-550/10T	80×120×150	30	80×120×170	35
U 9SL/SLX-200/4-400/7T	80×120×155	25	80×120×185	30
U 9SL/SLX-450/8 T-550/10T	85×110×150	20	85×110×150	20
U 18SL/SLX-250/3 T-400/4T	80×120×155	25	80×120×185	30
U 18SL/SLX-450/5 T-550/6T	85×110×150	20	85×110×150	20
U 18SL/SLX-750/8 T-900/6T	85×110×150	20	85×110×150	20



ULTRA V-SV-L-SL-LG-SLG Serie-Mechanical seal and bearings

MECHANICAL SEAL	PUMP MODEL	SHAFT Ø		STANDARD MATERIAL	OPTIONAL
					2
	U3-100/5, U3-120/6, U5-120/4, U5-150/5, U5-180/6, U7-180/4, U7-250/5, U7-300/6, U9-200/4, U9-250/5, U18-250/3, U18-400/4	14mm / S	Rotating face Stationary face Elastomer	Graphite Ceramic EPDM	SiC SiC EPDM
	U3-150/7, U3-180/8, U3-200/9, U3-250/10, U3-280/11, U3-300/12, U5-200/7, U5-250/8, U5-280/9, U5-300/10, U5-350/11, U5-380/12, U7-350/7, U7-400/8, U7-450/9, U7-550/10, U9-300/6, U9-400/7, U9-450/8, U9-500/9, U9-550/10	14mm	Rotating face Stationary face Elastomer	Graphite SiC EPDM	SiC SiC EPDM
	U18-450/5, U18-550/6, U18-750/8, U18-900/9, U18-920/10, U18-1000/11	14mm / L	Rotating face Stationary face Elastomer	Graphite SiC EPDM	SiC SiC EPDM
	U3-350/14, U3-380/16, U3-400/18, U3-450/20, U5-400/14, U5-450/16, U5-550/18, U5-600/20, U7-750/12, U7-800/14, U7-900/16, U7-950/18, U7-1000/20, U9-750/12, U9-800/14, U9-900/16, U9-950/18, U9-1000/20	14mm / Balanced seal	Rotating face Stationary face Elastomer	Tungsten carbide Graphite EPDM	- - -

BEARINGS	PUMP MODEL	TYPE	
	U3-100/5, U3-120/6, U5-120/4	6202-ZZ	6302-ZZ C3
	U3-150/7, U3-180/8, U3-200/9, U3-250/10, 3- U3-280/11, 3- U3-300/12, U5-150/5, U5-180/6, U5-200/7, U5-250/8, 3- U5-280/9, 3- U5-300/10, U7-180/4, U7-250/5, 3- U7-300/6, U9-200/4, U9-250/5, 3- U9-300/6, U18-250/3	6203-ZZ	6304-ZZ C3
	1- U3-280/11, 1- U3-300/12, 1- U5-280/9, 1- U5-300/10, U5-350/11, U5-380/12, 1- U7-300/6, U7-350/7, U7-400/8, 1- U9-300/6, U9-400/7, U18-400/4, U3-350/14, U3-380/16, U3-400/18, U5-400/14	6203-ZZ	6305-ZZ C3
	U7-450/9, U7-550/10, U9-450/8, U9-500/9, U9-550/10, U18-450/5, U18-550/6	6204-ZZ	6306-ZZ-C3
	U3-450/20, U5-450/16, U5-550/18, U5-600/20	6204-ZZ	3206-ZZ C3
	U7-750/12, U7-800/14, U7-900/16, U9-750/12, U9-800/14, U9-900/16, U18-750/8, U18-900/9, U18-920/10	6206-ZZ C3	3306-ZZ C3
	U7-950/18, U7-1000/20, U9-950/18, U9-1000/20, U18-1000/11	6206-ZZ C3	3308-ZZ C3

